

The test DVDs come as a compendium of several DVDs with professional test patterns and test data streams for audio, video and EMC applications relating to DVD players. These include measurements of video and audio quality, automatic error correction tests, reliability and laser tests, as well as test patterns for subjective quality assessment. Used in conjunction with audio and video analyzers or EMC test systems from Rohde & Schwarz, the DVDs also enable fully automatic quality measurement and analysis of DVD equipment.

Professional Test DVDs

Video and audio test signals for professional applications

Test signals of utmost quality

In many cases, measurement quality is determined to a considerable extent by the scope and quality of the test signals used. The DVD compendium – jointly created by Rohde & Schwarz and BUROSCH – offers a unique compilation of many different video and audio test signals for professional applications including:

- ◆ Precompliance measurements on video and audio equipment
- ◆ Objective measurement and assessment of video and audio signals used in DVD equipment, for example by means of video and audio analyzers from Rohde & Schwarz
- ◆ Subjective quality tests of video and audio equipment

- ◆ Type approval tests in accordance with international standards, e.g. using EMS Test System R&S TS9980, to determine electromagnetic susceptibility of sound and TV broadcast receivers as well as satellite and DVB receivers

Particular importance was attached to the digital test sequences meeting exacting quality standards. Offering a choice of suitable picture structures and audio frequencies, the test sequences allow standard-conforming measurements of maximum quality as well as the subjective assessment of audio and video equipment.

The compendium, which comes in two separate versions for PAL and NTSC, comprises three albums for different

types of tests. Album 1 contains over 100 different test patterns as well as video and audio sequences on a video DVD for picture quality assessment, including EMS measurements. Album 2 contains a video DVD and an audio DVD supplying stereo and multichannel test sequences for audio quality assessment. Album 3 comprises two DVDs with data streams for testing the reliability of systems containing DVD components, including automatic error correction tests and endurance tests of DVD equipment.



Measuring the signal and video quality

Automatic video quality measurements

DVD players often feature a wide variety of video outputs. Many players not only offer CCVS signal outputs to PAL or NTSC, but also RGB and YCbCr component signal outputs as well as a YC S-video signal output. In addition, video signals can be output with 525 or 625 lines and with aspect ratio 4:3 or 16:9. Reliable quality assessment for such a wealth of signals calls for professional video test equipment, for example Video Measurement System R&S VSA or Video Analyzer R&S UAF from Rohde&Schwarz (FIG 1). Test DVD 1 delivers all the necessary signals with the levels and timing conforming to the standards. Main measurements include:

- ◆ Level
- ◆ Linear and nonlinear distortions
- ◆ Chrominance/luminance delays
- ◆ Levels and delays of components relative to one another
- ◆ S/N ratio
- ◆ Timing

Utmost care was taken to avoid any artefacts being generated in signal coding, and thus avoid any impairments to measurement quality. The most important signals are combined in test pat-

terns, allowing a wide variety of measurements to be performed in just a few seconds without any tedious switchovers being required on the DVD player (see Codec 43 test pattern in box on page 31). This enables extensive testing of video and audio signal outputs

even during short production cycles. Plus, comprehensive measurement series carried out for comparing different products can be speeded up considerably. No extra time is required for configuring the Rohde&Schwarz video analyzers. In addition to the main test sig-

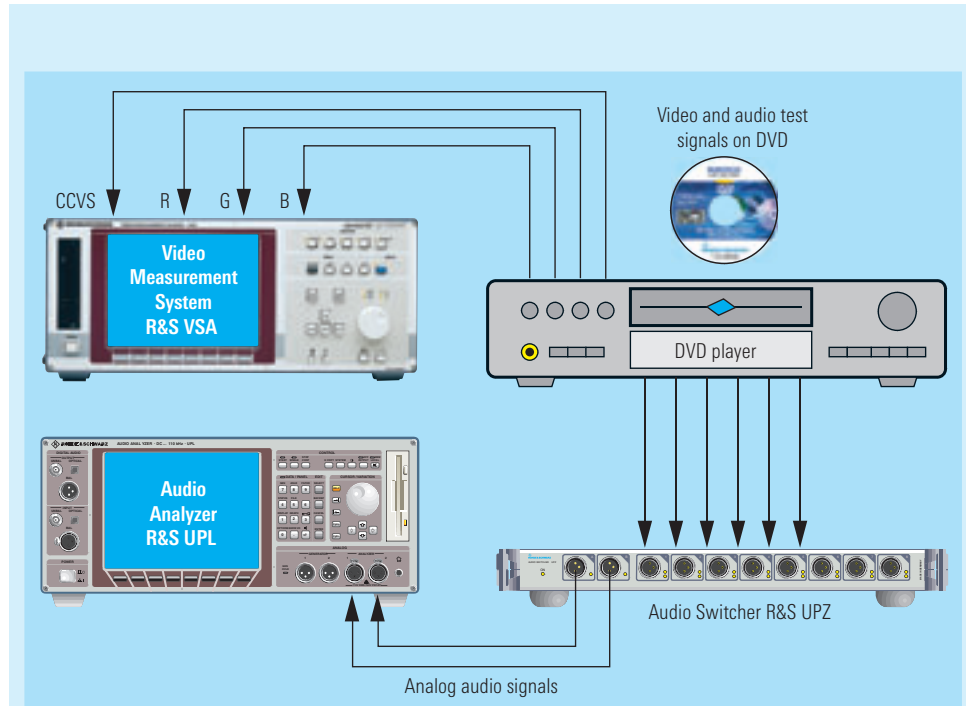

FIG 1 Test setup for automatic measurements of video and audio data streams.

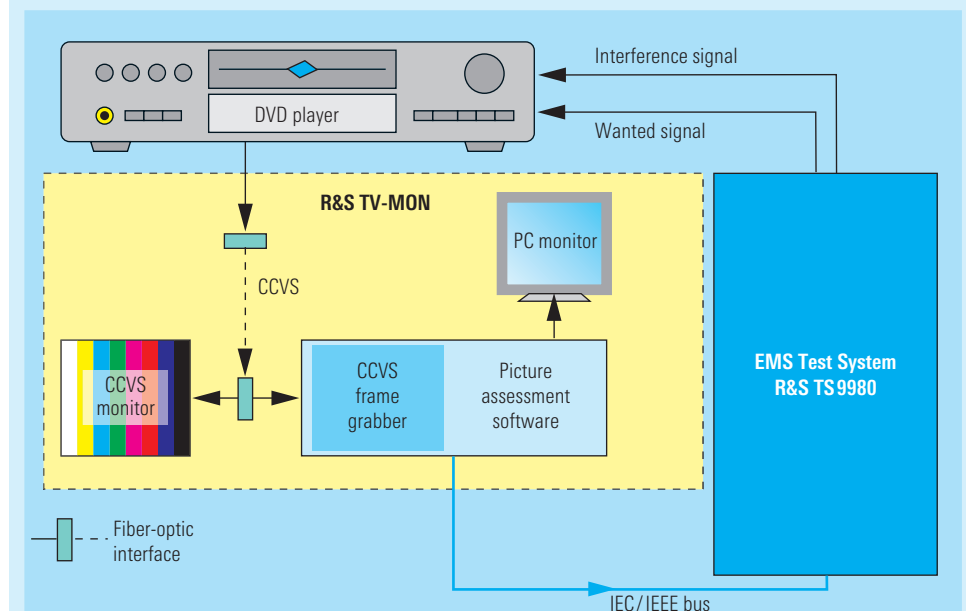

FIG 2 Configuration of EMS Test System R&S TS9980 with R&S TV-MON option for automatic picture assessment during EMS measurements.

► nals, the Codec test pattern comprises moving elements that provide information on whether the correct TV standard was set on the DVD player, or whether decoding errors occur. Moreover, a 30 s CCITT 0.33 audio sequence is added to the test pattern, thus allowing important audio measurements to be carried out along with the video measurements in a single test cycle.

Most of the video sequences also contain audio signals ranging from 997 Hz reference signals and pink noise up to AC-3 test signals for simultaneous and complete assessment of audio and video streams.

EMS measurements with automatic picture assessment

The video DVD (DVD 1) contains a special menu supporting EMS measurements, e.g. by means of Test System R&S TS9980 (FIG 2). For equipment under test (EUT) without an integrated monitor, the optional R&S TV-MON system extension enables direct assessment of the CCVS signal, i.e. the detection of analog and digital picture degradations such as moiré patterns, contrast degradation, sync loss or blocking. The test sequence for objective and automatic picture assessment is based on the ITU-R BT.801-1 colour bar test pattern, into which a moving element is introduced so that data stream interruptions can be identified.

Subjective picture quality assessment

The test patterns not only allow the automatic evaluation of data streams but also subjective video quality assessment. This is supported by numerous video sequences including:

- ◆ Sequences containing elements with rotating or back-and-forth motion for the assessment of smearing effects on monitors, TFT displays, plasma tubes or projectors as contrasted with conventional TV picture tubes

- ◆ Special video test data streams such as zone-plate signals that support the visual assessment of artefacts generated in scaling conversion
- ◆ Portraits of persons against different backgrounds for assessment of contrast and skin colour reproduction
- ◆ Video streams representing landscapes, e.g. a forest, to test the MPEG decoder performance

The video test sequences are available for the 4:3 and 16:9 aspect ratios.



DVD 2/3

Automatic measurements of audio signals

To meet the different requirements of the video and audio DVD standards, the audio test data streams are provided both on a video and an audio DVD (DVDs 2/3). The audio DVD standard allows audio test signals to be stored loss-free. In line with this standard, the audio DVD (DVD 3) contains PCM coded audio files in different formats (e.g. 192 kHz/24 bit stereo and 48 kHz/24 bit 5.1 multichannel). These files are also available on the video DVD (DVD 2) in 48 kHz/16 bit and 96 kHz/24 bit stereo format; in addition, the video DVD contains encoded test files in Dolby Digital and DTS 5.1 format.

The audio signals on the two DVDs allow the exact determination of multichannel frequency response as well as the accurate measurement of S/N ratios and distortions. In addition, numerous test sequences are available for the control of discrete channels, for example to test downmix functions or loudspeaker parameters set in the decoder.

The DVDs contain pulse code modulated (PCM) test signals with various sampling rates as well as coded audio signals (Dolby Digital, DTS). These signals allow the full range of audio parameters to be

tested, including frequency response, distortion, S/N ratio, linearity, crosstalk, etc. For many of these measurements, setups or macros are available on the Audio Analyzer R&S UPL for the performance of automatic test sequences.



DVD 4

Testing error correction capacity

DVD 4 (video) has been specially compiled for testing the laser characteristics and the error correction capacity. The various error correction parameter values can be accurately determined by introducing picture degradation and steadily increasing it. The error correction capacity can also be assessed visually.

Where test series are to be performed for a large number of EUTs, it is advisable to use the Digital Video Quality Analyzer R&S DVQ, which is connected to the EUT via a converter that transforms the analog RGB component signals to digital signals to ITU-601. The R&S DVQ automatically logs picture degradations together with the time of their occurrence, so eliminating the need for continuous picture monitoring.



DVD 5

Reliability tests

Apart from user-friendly operation and high video and audio quality, long-term reliability is the most important quality requirement to be met by DVD players. Visual monitoring of video sequences carried out during quality inspection only yields sample results; it does not provide coherent results that would allow complete quality assessment over several hours. DVD 5 (video), therefore, delivers a continuous test signal by which picture degradations (e.g. picture freeze or picture loss) can be automatically detected by means of the Digital Video Quality Analyzer R&S DVQ. Reliabil-

ity tests can thus be implemented that allow DVD players to be tested to their limits of performance, for example by putting EUTs through temperature cycles at the same time.

Summary

The test DVD compendium is a comprehensive compilation of test patterns, video data streams and audio signals for professional quality assessment of the audio and video data streams of DVD equipment. Particularly noteworthy is the fact that, besides supplying a variety of professional test signals, the compilation for the first time offers a test DVD to the DVD audio standard.

The R&S Professional Test DVDs are available separately for the PAL and NTSC systems.

Regional code 0 ensures that the test signals can be used on a variety of DVD systems regardless of their regional code number.

The DVD compendium is provided by Rohde & Schwarz and BURSCH with support from the audiovision T&M journal and the TESTfactory test lab of the Video T&M journal.

Gert Heuer

Descriptions of the data streams can be downloaded from the Internet address www.testdvd.rohde-schwarz.com from November 2002. For more information, refer to the address www.professional-dvd.de. Information on the instruments and test systems mentioned in this article is available at the Rohde & Schwarz website (search term: type designation of instrument/system).

Examples of test patterns and video data streams provided by the DVDs

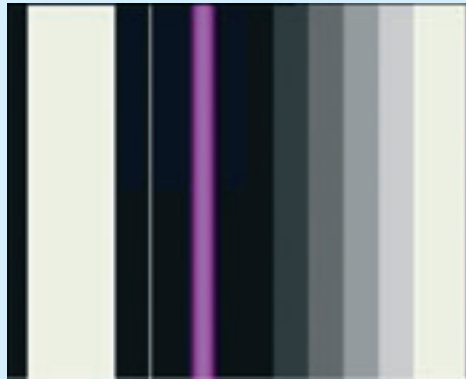

CCIR17 for measuring nonlinearities, level and group-delay errors.

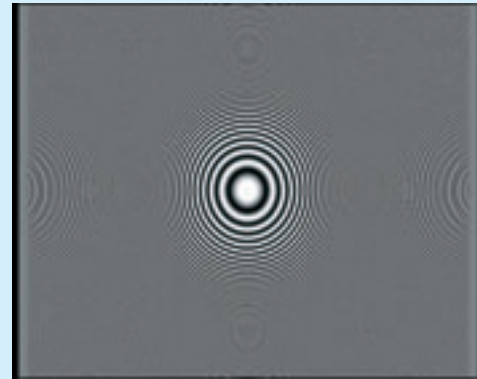

Zone-plate signal supports visual assessment of artefacts generated in scaling conversion.

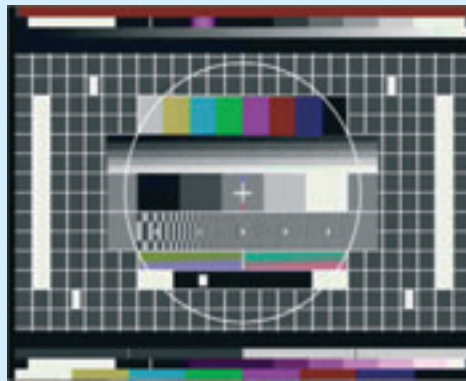

Codec 43 combines many different test signals in one pattern for simultaneous, automatic measurement of significant parameters of a video signal.



ITU-R BT.801-1 colour bar test pattern with moving element for automatic picture assessment during EMS measurements.

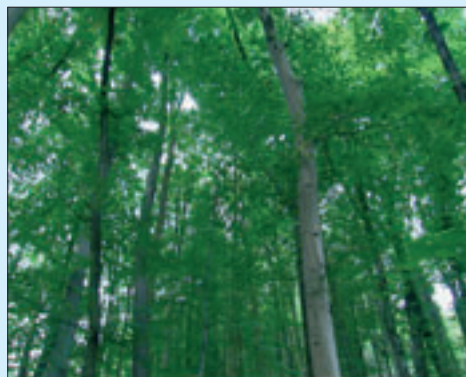

Forest pattern for testing MPEG decoder performance.



Portrait against white background for assessment of contrast and skin colour reproduction.